



ABSOLYTE™

MARATHON™

Sprinter®

Classic™

Powerfit™



Présent dans plus de 80 pays, Exide Technologies est le leader sur le marché du stockage d'énergie. À l'origine depuis plus d'un siècle de la plupart des progrès réalisés en matière de technologie d'accumulateurs électriques, Exide Technologies crée des " Solutions Energie " qui s'intègrent au mieux dans les véhicules électriques, les engins de manutention et les systèmes d'alimentation électrique de secours pour les télécommunications, les applications ferroviaires, photovoltaïques (énergie solaire), informatiques (UPS).

Exide Technologies est fier de son engagement pour un meilleur environnement et contribue activement au programme - Total Battery Management - pour assurer un cycle de vie sûr et responsable de l'ensemble de ses produits. Ce programme prend en considération une approche globale dans la fabrication, la distribution et le recyclage des batteries au plomb.

Siège

CEAC – Compagnie Européenne d'Accumulateurs - Groupe Exide Technologies
5 allée des Pierres Mayettes - 92636 Gennevilliers Cedex - Tél.: 01 41 21 23 00
Société par Actions Simplifiée au capital de 38 524 860 € - RCS Nanterre B 682030895 – NAF 518J

Agences commerciales

ILE DE FRANCE/NORD
92636 Gennevilliers Cedex
Tél.: 01 41 21 23 00 - Fax : 01 41 21 27 87

SUD-EST
13127 Vitrolles
Tél.: 04 42 75 33 00 - Fax : 04 42 89 96 77

Siège Belgique

EXIDE BELGIUM bvba/sprl - Veldkant 35c-B-2550 Kontich - Belgique
Tél.: +32 3 460 1300 - Fax : +32 3 455 6907

www.industrialenergy.exide.com

EXIDE
TECHNOLOGIES



Batteries Industrielles Classic OPzS

Classic OPzS

Une alimentation de secours sûre

Applications

Les batteries Classic OPzS apportent des solutions d'énergie fiables et universelles pour les systèmes de télécommunications, les réseaux d'alimentation et de distribution électriques, les systèmes d'alarme et de sécurité, ainsi que pour tous les systèmes d'alimentation de secours.



Classic OPzS

L'expérience à votre service

Spécifications

- Les batteries Classic OPzS sont des batteries ouvertes faible entretien à électrolyte liquide réputées depuis des décennies pour leur fiabilité, leur robustesse et leur longue durée de vie.
- Faible entretien grâce à un alliage à faible taux d'antimoine et une grande réserve d'électrolyte.
- Capacité nominale de 50 Ah à 3350 Ah C₁₀.
Jusqu'à 12000 Ah sur demande.
- Durée de vie à 20° C
 - 15 ans pour les monoblocs 6 et 12 V et les éléments ≥ 3500 Ah.
 - 20 ans pour les éléments 2V de 125-3350 Ah.
 (capacité nominale résiduelle 80 %).
- Également utilisable en application cyclage.
- Bac en plastique transparent haute qualité (monobloc : ABS – Élément : SAN).
- Plaques tubulaires en élément 2V et monobloc 6V et 12V.
- Également disponible en version chargé sec avec électrolyte séparé.
- Faible dégagement gazeux grâce à un taux d'antimoine <3%.
- En conformité avec la norme DIN 40736 et DIN 40737 T3.
- Électrolyte : Densité acide sulfurique dilué = 1.24 Kg/l.
- Capacités accrues par rapport à la norme DIN grâce à une conception optimisée des plaques.
- Produit recyclable.

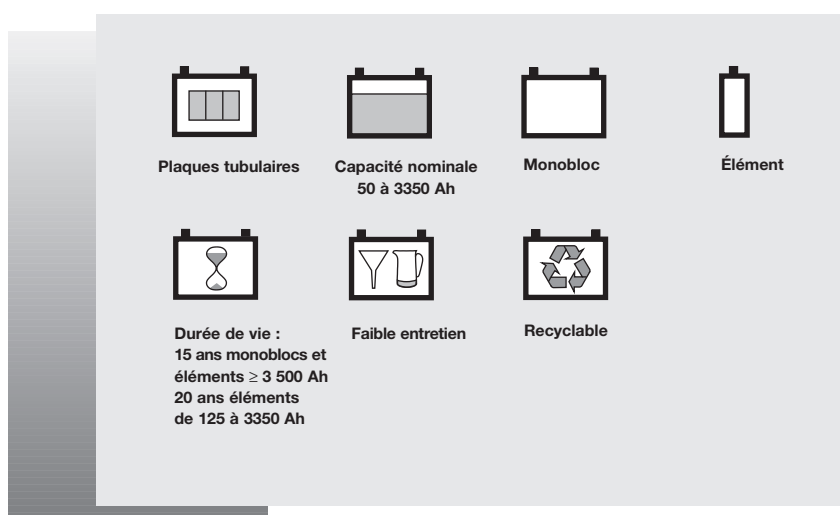

OPzS bloc

Type suivant DIN 40 737 T3	Codification	Tension nominale	Capacité nominale C ₁₀ 1.8 V/elt 20°C	Longueur (L) max.	Largeur (l) max.	Hauteur* (h) max.	Longueur installée (L/l)	Poids monobloc acide inclus	Poids acide**	Résistance interne m Ω / élément	Courant de court-circuit	Bornes de sortie	Nbre de sorties (paire)
		V	Ah	mm	mm	mm	mm	kg	kg	m Ω	A		
12V 1 OPzS 50 LA	NVZS120050WC0FA	12	50	275	208	385	285	35	15	18.18	688	F-M8	1
12V 2 OPzS 100 LA	NVZS120100WC0FA	12	100	275	208	385	285	45	14	9.26	1314	F-M8	1
12V 3 OPzS 150 LA	NVZS120150WC0FA	12	150	383	208	385	393	64	19	6.46	1884	F-M8	1
6V 4 OPzS 200 LA	NVZS060200WC0FA	6	200	275	208	385	285	41	13	2.68	2283	F-M8	1
6V 5 OPzS 250 LA	NVZS060250WC0FA	6	250	383	208	385	393	56	20	2.39	2800	F-M8	1
6V 6 OPzS 300 LA	NVZS060300WC0FA	6	300	383	208	385	393	63	20	1.96	3106	F-M8	1

* La hauteur indiquée peut varier en fonction des bouchons utilisés.

** Densité nominale acide 1,24 kg/l

Les données sont aussi valables en version chargé sec. Remplacer W (chargé liquide) par D (chargé sec)
 Exemple :
 Chargé liquide : NVZS120050**W**C0FA
 Chargé sec : NVZS120050**D**C0FA

Bac, sortie et couple de serrage

Bac/couvercle ABS

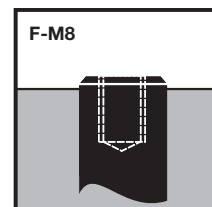

20Nm

Dessin avec position des sorties

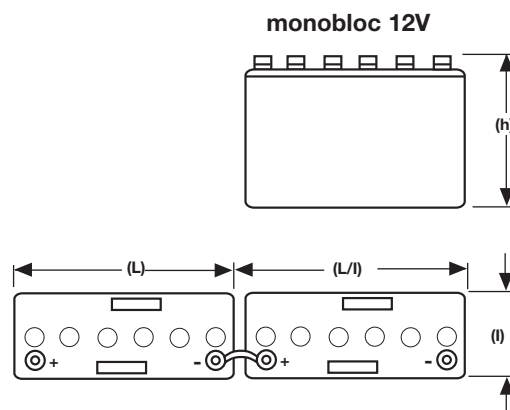
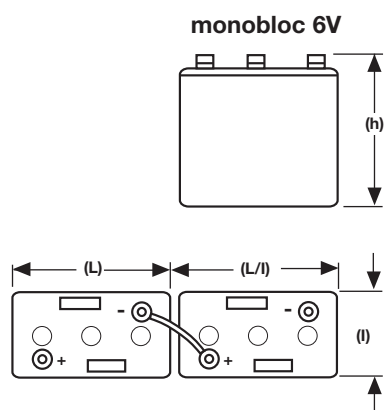

Éléments OPzS

Type suivant DIN 40 736 T1	Codification	Tension nominale	Capacité nominale C_{10} 1.8 V/elt 20°C Ah	Longueur (L)	Largeur (l)	Hauteur* (h)	Longueur installée (L/l)	Poids élément acide inclus	Poids acide**	Résistance interne m Ω /élément	Courant de court-circuit	Bornes de sortie	Nbre de sorties (paire)
		V		max. mm	max. mm	max. mm	mm	kg	kg	m Ω	A	F-M8	
2 OPzS 100 LA	NVZS020100WC0FA	2	125	105	208	405	115	13.7	5.2	1.45	1400	F-M8	1
3 OPzS 150 LA	NVZS020150WC0FA	2	165	105	208	405	115	15.2	5.0	1.05	1950	F-M8	1
4 OPzS 200 LA	NVZS020200WC0FA	2	210	105	208	405	115	16.6	4.6	0.83	2450	F-M8	1
5 OPzS 250 LA	NVZS020250WC0FA	2	260	126	208	405	136	20.0	5.8	0.72	2850	F-M8	1
6 OPzS 300 LA	NVZS020300WC0FA	2	310	147	208	405	157	23.3	6.9	0.63	3250	F-M8	1
5 OPzS 350 LA	NVZS020350WC0FA	2	380	126	208	520	136	26.7	8.1	0.63	3250	F-M8	1
6 OPzS 420 LA	NVZS020420WC0FA	2	455	147	208	520	157	31.0	9.3	0.56	3650	F-M8	1
7 OPzS 490 LA	NVZS020490WC0FA	2	530	168	208	520	178	35.4	10.8	0.50	4100	F-M8	1
6 OPzS 600 LA	NVZS020600WC0FA	2	680	147	208	695	157	43.9	13.0	0.47	4350	F-M8	1
7 OPzS 700 LA	NVZS020700WC0FA	2	750	147	208	695	157	47.2	12.8	0.43	4800	F-M8	1
8 OPzS 800 LA	NVZS020800WC0FA	2	910	215	193	695	225	59.9	17.1	0.30	6800	F-M8	2
9 OPzS 900 LA	NVZS020900WC0FA	2	980	215	193	695	225	63.4	16.8	0.27	7500	F-M8	2
10 OPzS 1000 LA	NVZS021000WC0FA	2	1140	215	235	695	225	73.2	21.7	0.26	7900	F-M8	2
12 OPzS 1200 LA	NVZS021200WC0FA	2	1370	215	277	695	225	86.4	26.1	0.23	8900	F-M8	2
12 OPzS 1500 LA	NVZS021500WC0FA	2	1700	215	277	845	225	108.0	33.7	0.24	8500	F-M8	2
14 OPzS 1750 LA	NVZS021750WC0FA	2	1800	215	277	845	225	114.0	32.7	0.22	9300	F-M8	2
16 OPzS 2000 LA	NVZS022000WC0FA	2	2250	215	400	815	225	151.0	50.0	0.16	12800	F-M8	3
18 OPzS 2250 LA	NVZS022250WC0FA	2	2450	215	400	815	225	158.0	48.0	0.14	14600	F-M8	3
20 OPzS 2500 LA	NVZS022500WC0FA	2	2800	215	490	815	225	184.0	60.0	0.12	17000	F-M8	4
22 OPzS 2750 LA	NVZS022750WC0FA	2	3000	215	490	815	225	191.0	58.0	0.11	17800	F-M8	4
24 OPzS 3000 LA	NVZS023000WC0FA	2	3350	215	580	815	225	217.0	71.0	0.11	18600	F-M8	4

* La hauteur indiquée peut varier en fonction des bouchons utilisés.

** Densité nominale acide 1,24 kg/l

Les données sont aussi valables en version chargé sec. Remplacer W (chargé liquide) par D (chargé sec)

Exemple :

Chargé liquide : NVZS020200**W**C0FA

Chargé sec : NVZS020200**D**C0FA

Bac, sortie et couple de serrage

Bac/couvercle : SAN (Styrèneacrylonitrile)

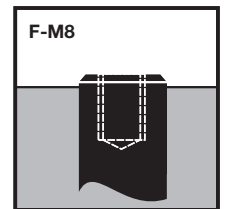

20Nm

Dessin avec position des sorties

2 OPzS 100 LA
à 7 OPzS 700 LA

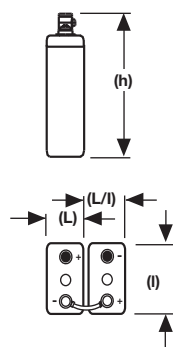

8 OPzS 800 LA
à 14 OPzS 1750 LA

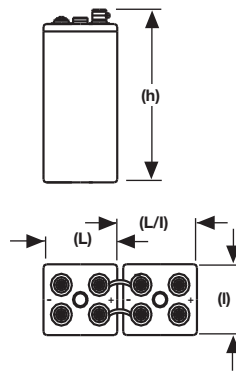

16 OPzS 2000 LA
à 18 OPzS 2250 LA

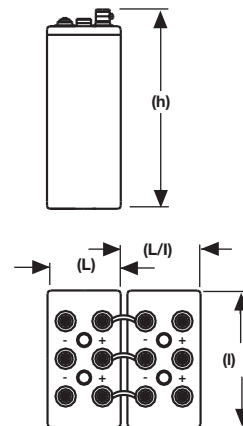

20 OPzS 2500 LA
à 24 OPzS 3000 LA

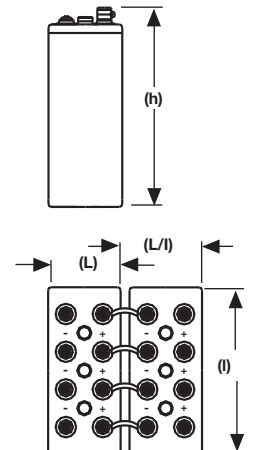

Monobloc OPzS

1,90 V/elt – Décharge en A à 20°C													
Type	Codification	5min	10min	15min	30min	1h	2h	3h	4h	5h	6h	8h	10h
12V 1 OPzS 50 LA	NVZS120050WC0FA	32.0	29.0	25.0	21.3	16.1	11.7	9.7	8.2	7.0	6.3	5.6	5.0
12V 2 OPzS 100 LA	NVZS120100WC0FA	66.5	58.0	52.2	41.5	31.5	24.5	17.4	15.0	13.7	12.5	10.6	8.9
12V 3 OPzS 150 LA	NVZS120150WC0FA	99.0	84.0	76.0	64.0	47.2	34.1	26.4	22.3	19.7	17.7	14.6	12.0
6V 4 OPzS 200 LA	NVZS060200WC0FA	120.0	105.0	96.0	85.0	62.0	46.0	35.3	30.0	26.7	24.1	19.8	16.1
6V 5 OPzS 250 LA	NVZS060250WC0FA	145.0	132.0	122.0	102.0	70.0	56.0	43.5	34.0	32.0	29.0	25.2	21.7
6V 6 OPzS 300 LA	NVZS060300WC0FA	160.0	147.0	136.0	118.0	91.0	66.0	53.0	45.3	39.0	34.0	28.0	24.5

1,87 V/elt – Décharge en A à 20°C													
Type	Codification	5min	10min	15min	30min	1h	2h	3h	4h	5h	6h	8h	10h
12V 1 OPzS 50 LA	NVZS120050WC0FA	40.0	35.0	31.0	25.5	19.4	13.6	11.2	9.3	8.2	7.2	6.0	5.5
12V 2 OPzS 100 LA	NVZS120100WC0FA	80.0	70.0	62.0	50.0	37.9	27.2	19.9	16.9	15.2	13.7	11.5	9.5
12V 3 OPzS 150 LA	NVZS120150WC0FA	120.0	102.0	90.0	75.0	55.0	39.5	30.0	25.4	22.0	19.8	16.4	13.8
6V 4 OPzS 200 LA	NVZS060200WC0FA	150.0	132.0	120.0	100.0	72.4	52.0	40.0	33.2	29.4	26.8	22.2	18.0
6V 5 OPzS 250 LA	NVZS060250WC0FA	180.0	161.0	140.0	118.0	88.7	63.2	50.0	42.0	36.7	33.4	28.1	23.3
6V 6 OPzS 300 LA	NVZS060300WC0FA	195.0	176.0	160.0	135.0	104.0	76.5	59.2	51.0	44.0	38.0	32.0	27.0

1,85 V/elt – Décharge en A à 20°C													
Type	Codification	5min	10min	15min	30min	1h	2h	3h	4h	5h	6h	8h	10h
12V 1 OPzS 50 LA	NVZS120050WC0FA	44.0	39.0	35.0	28.2	21.0	14.2	11.7	9.8	8.5	7.5	6.3	5.6
12V 2 OPzS 100 LA	NVZS120100WC0FA	87.5	78.0	69.5	55.0	41.0	28.8	21.4	17.8	15.6	14.3	11.8	9.7
12V 3 OPzS 150 LA	NVZS120150WC0FA	130.0	112.0	102.5	81.0	59.8	42.0	31.5	27.1	23.0	20.7	17.1	14.2
6V 4 OPzS 200 LA	NVZS060200WC0FA	162.0	145.0	135.0	110.0	78.7	55.5	42.2	35.0	30.8	28.1	23.3	18.7
6V 5 OPzS 250 LA	NVZS060250WC0FA	193.0	175.0	155.0	126.0	93.4	67.0	52.5	44.5	38.2	35.1	29.3	23.7
6V 6 OPzS 300 LA	NVZS060300WC0FA	216.0	195.0	177.0	147.0	113.5	79.0	62.0	54.0	46.0	40.5	33.7	28.0

1,83 V/elt – Décharge en A à 20°C													
Type	Codification	5min	10min	15min	30min	1h	2h	3h	4h	5h	6h	8h	10h
12V 1 OPzS 50 LA	NVZS120050WC0FA	48.0	43.0	39.0	31.0	22.8	15.3	12.2	10.2	8.8	7.8	6.5	5.8
12V 2 OPzS 100 LA	NVZS120100WC0FA	95.0	85.0	77.0	60.0	44.0	30.6	22.8	18.6	16.1	14.6	12.1	10.0
12V 3 OPzS 150 LA	NVZS120150WC0FA	140.0	122.0	115.0	87.0	64.6	44.4	33.4	28.3	24.1	21.6	17.9	14.6
6V 4 OPzS 200 LA	NVZS060200WC0FA	175.0	158.0	150.0	120.0	85.0	59.1	44.5	36.7	32.3	29.2	24.0	19.5
6V 5 OPzS 250 LA	NVZS060250WC0FA	207.0	190.0	171.0	135.0	102.0	71.4	55.0	46.5	40.3	36.3	30.2	24.5
6V 6 OPzS 300 LA	NVZS060300WC0FA	237.0	213.0	195.0	160.0	123.0	85.7	66.3	56.5	48.3	42.5	34.8	29.0

1,80 V/elt – Décharge en A à 20°C													
Type	Codification	5min	10min	15min	30min	1h	2h	3h	4h	5h	6h	8h	10h
12V 1 OPzS 50 LA	NVZS120050WC0FA	57.0	49.0	44.0	34.0	25.2	17.1	13.5	11.0	9.5	8.2	6.9	5.9
12V 2 OPzS 100 LA	NVZS120100WC0FA	110.0	96.0	85.0	66.0	49.0	32.3	24.1	19.6	17.1	15.4	12.5	10.1
12V 3 OPzS 150 LA	NVZS120150WC0FA	160.0	135.0	120.0	95.0	70.4	47.1	36.0	29.8	25.7	22.7	18.6	15.0
6V 4 OPzS 200 LA	NVZS060200WC0FA	205.0	178.0	160.0	130.0	92.0	61.3	47.5	38.5	34.9	30.4	25.0	20.3
6V 5 OPzS 250 LA	NVZS060250WC0FA	240.0	212.0	190.0	150.0	110.0	74.5	59.2	49.0	42.8	37.8	31.2	25.5
6V 6 OPzS 300 LA	NVZS060300WC0FA	260.0	240.0	218.0	177.0	135.0	89.3	70.4	59.5	51.0	44.5	35.8	30.3

Monobloc OPzS

1,75 V/elt – Décharge en A à 20°C													
Type	Codification	5min	10min	15min	30min	1h	2h	3h	4h	5h	6h	8h	10h
12V 1 OPzS 50 LA	NVZS120050WC0FA	65.0	56.0	48.0	36.0	26.5	18.4	14.0	11.6	9.8	8.6	7.2	6.2
12V 2 OPzS 100 LA	NVZS120100WC0FA	125.0	109.0	95.0	71.0	51.3	34.0	25.9	20.8	18.2	16.2	13.0	10.2
12V 3 OPzS 150 LA	NVZS120150WC0FA	185.0	155.0	136.0	102.0	73.4	50.0	37.5	31.2	27.0	24.0	19.4	15.3
6V 4 OPzS 200 LA	NVZS060200WC0FA	235.0	206.0	185.0	140.0	97.9	66.0	50.0	40.5	35.8	31.2	25.7	20.4
6V 5 OPzS 250 LA	NVZS060250WC0FA	285.0	250.0	220.0	165.0	120.0	81.0	62.0	51.0	44.0	39.1	32.3	26.1
6V 6 OPzS 300 LA	NVZS060300WC0FA	340.0	295.0	260.0	200.0	143.0	98.3	74.5	62.0	52.5	45.8	36.8	30.6

1,70 V/elt – Décharge en A à 20°C													
Type	Codification	5min	10min	15min	30min	1h	2h	3h	4h	5h	6h	8h	10h
12V 1 OPzS 50 LA	NVZS120050WC0FA	75.0	62.0	54.0	39.0	27.3	18.5	14.4	11.8	10.0	8.7	7.3	6.3
12V 2 OPzS 100 LA	NVZS120100WC0FA	145.0	122.0	106.0	78.0	54.0	35.0	26.7	21.3	18.8	16.6	13.3	10.4
12V 3 OPzS 150 LA	NVZS120150WC0FA	210.0	174.0	155.0	115.0	79.3	52.0	38.6	32.0	28.2	24.8	19.9	15.6
6V 4 OPzS 200 LA	NVZS060200WC0FA	270.0	232.0	208.0	155.0	108.0	68.0	51.6	41.5	37.5	31.7	26.0	20.8
6V 5 OPzS 250 LA	NVZS060250WC0FA	340.0	287.0	255.0	183.0	131.0	84.0	63.5	52.3	45.0	40.1	33.0	26.5
6V 6 OPzS 300 LA	NVZS060300WC0FA	380.0	333.0	295.0	220.0	159.0	103.0	77.0	63.6	53.5	46.4	37.3	31.2

1,67 V/elt – Décharge en A à 20°C													
Type	Codification	5min	10min	15min	30min	1h	2h	3h	4h	5h	6h	8h	10h
12V 1 OPzS 50 LA	NVZS120050WC0FA	80.0	66.0	56.0	40.0	27.7	18.7	14.5	11.9	10.0	8.8	7.3	6.3
12V 2 OPzS 100 LA	NVZS120100WC0FA	156.0	130.0	111.0	81.0	55.0	35.3	26.8	21.6	18.9	16.8	13.4	10.4
12V 3 OPzS 150 LA	NVZS120150WC0FA	229.0	186.0	163.0	118.0	82.0	52.6	39.0	32.2	28.5	25.2	20.1	15.7
6V 4 OPzS 200 LA	NVZS060200WC0FA	293.0	247.0	219.0	160.0	111.0	68.5	52.5	41.8	36.1	32.0	26.1	21.0
6V 5 OPzS 250 LA	NVZS060250WC0FA	362.0	307.0	268.0	193.0	133.0	84.5	63.9	52.6	45.6	40.5	33.3	26.6
6V 6 OPzS 300 LA	NVZS060300WC0FA	417.0	355.0	315.0	231.0	163.0	105.0	78.0	64.1	54.0	46.6	37.5	31.3

1,65 V/elt – Décharge en A à 20°C													
Type	Codification	5min	10min	15min	30min	1h	2h	3h	4h	5h	6h	8h	10h
12V 1 OPzS 50 LA	NVZS120050WC0FA	83.0	68.0	58.0	41.0	27.9	18.8	14.5	11.9	10.0	8.8	7.3	6.3
12V 2 OPzS 100 LA	NVZS120100WC0FA	162.0	135.0	115.0	83.0	55.5	35.5	26.9	21.7	19.0	16.9	13.5	10.4
12V 3 OPzS 150 LA	NVZS120150WC0FA	240.0	193.0	168.0	120.0	83.0	53.0	39.2	32.4	28.6	25.5	20.2	15.7
6V 4 OPzS 200 LA	NVZS060200WC0FA	307.0	258.0	226.0	163.0	113.0	69.0	52.9	42.0	36.2	32.2	26.2	21.0
6V 5 OPzS 250 LA	NVZS060250WC0FA	380.0	320.0	278.0	189.0	135.0	85.0	64.1	52.8	46.0	40.8	33.4	26.6
6V 6 OPzS 300 LA	NVZS060300WC0FA	435.0	369.0	326.0	237.0	165.0	106.0	78.5	64.4	54.2	46.8	37.6	31.3

Eléments OPzS

1,87 V/elt – Décharge en A à 20°C															
Type	Codification	3min	10min	15min	20min	30min	1h	1h30	2h	3h	4h	5h	8h	10h	20h
2 OPzS 100 LA	NVZS020100WC0FA	82.4	81.1	76.0	71.5	65.2	51.2	42.7	36.3	28.6	23.4	20.0	14.1	11.7	6.3
3 OPzS 150 LA	NVZS020150WC0FA	106.0	105.0	98.5	91.6	83.4	66.2	55.3	47.5	37.3	30.6	26.2	18.6	15.4	8.4
4 OPzS 200 LA	NVZS020200WC0FA	135.0	134.0	125.0	118.0	107.0	84.3	70.4	60.4	47.5	39.0	33.3	23.7	19.7	10.6
5 OPzS 250 LA	NVZS020250WC0FA	163.0	161.0	151.0	142.0	130.0	103.0	86.3	74.5	58.2	47.9	41.1	29.2	24.3	13.2
6 OPzS 300 LA	NVZS020300WC0FA	189.0	186.0	175.0	166.0	152.0	121.0	102.0	88.4	68.7	56.5	48.7	34.7	29.0	15.7
5 OPzS 350 LA	NVZS020350WC0FA	190.0	187.0	180.0	174.0	160.0	135.0	115.0	99.8	79.8	66.5	57.8	41.7	34.8	19.3
6 OPzS 420 LA	NVZS020420WC0FA	216.0	214.0	207.0	201.0	186.0	157.0	135.0	118.0	95.6	79.7	69.2	50.0	41.7	23.1
7 OPzS 490 LA	NVZS020490WC0FA	247.0	245.0	236.0	229.0	213.0	179.0	156.0	136.0	111.0	92.5	80.6	58.2	48.5	26.9
6 OPzS 600 LA	NVZS020600WC0FA	279.0	277.0	267.0	257.0	239.0	207.0	181.0	163.0	131.0	111.0	98.5	72.9	62.3	34.5
7 OPzS 700 LA	NVZS020700WC0FA	307.0	305.0	295.0	284.0	264.0	228.0	200.0	179.0	144.0	123.0	109.0	80.4	68.7	38.0
8 OPzS 800 LA	NVZS020800WC0FA	403.0	396.0	378.0	365.0	337.0	290.0	252.0	222.0	178.0	152.0	134.0	98.1	83.4	46.1
9 OPzS 900 LA	NVZS020900WC0FA	430.0	427.0	407.0	393.0	363.0	312.0	271.0	239.0	192.0	164.0	144.0	106.0	89.8	49.7
10 OPzS 1000 LA	NVZS021000WC0FA	484.0	480.0	461.0	444.0	412.0	355.0	309.0	276.0	221.0	188.0	167.0	123.0	104.0	57.8
12 OPzS 1200 LA	NVZS021200WC0FA	562.0	558.0	538.0	518.0	482.0	416.0	365.0	328.0	264.0	225.0	198.0	147.0	125.0	69.5
12 OPzS 1500 LA	NVZS021500WC0FA	522.0	521.0	511.0	498.0	479.0	419.0	385.0	352.0	297.0	257.0	230.0	173.0	148.0	79.8
14 OPzS 1750 LA	NVZS021750WC0FA	553.0	552.0	541.0	532.0	508.0	444.0	408.0	372.0	314.0	272.0	245.0	183.0	157.0	84.5
16 OPzS 2000 LA	NVZS022000WC0FA	754.0	752.0	731.0	712.0	676.0	578.0	525.0	473.0	392.0	339.0	305.0	229.0	196.0	105.0
18 OPzS 2250 LA	NVZS022250WC0FA	791.0	789.0	769.0	748.0	712.0	615.0	561.0	507.0	427.0	370.0	333.0	249.0	213.0	115.0
20 OPzS 2500 LA	NVZS022500WC0FA	937.0	936.0	910.0	885.0	779.0	720.0	654.0	589.0	488.0	423.0	380.0	284.0	244.0	132.0
22 OPzS 2750 LA	NVZS022750WC0FA	1005.0	1005.0	976.0	949.0	903.0	771.0	700.0	631.0	523.0	453.0	407.0	305.0	262.0	141.0
24 OPzS 3000 LA	NVZS023000WC0FA	1080.0	1075.0	1050.0	1020.0	972.0	841.0	766.0	693.0	584.0	506.0	455.0	340.0	292.0	157.0

1,85 V/elt – Décharge en A à 20°C															
Type	Codification	3min	10min	15min	20min	30min	1h	1h30	2h	3h	4h	5h	8h	10h	20h
2 OPzS 100 LA	NVZS020100WC0FA	93.4	91.2	84.5	79.7	71.4	54.8	45.5	38.5	30.2	24.6	21.0	14.6	12.3	6.6
3 OPzS 150 LA	NVZS020150WC0FA	121.0	118.0	110.0	101.0	90.8	71.0	58.9	50.3	39.4	32.2	27.4	19.3	16.2	8.7
4 OPzS 200 LA	NVZS020200WC0FA	153.0	150.0	139.0	131.0	118.0	90.3	75.0	64.1	50.2	41.0	34.9	24.6	20.6	11.0
5 OPzS 250 LA	NVZS020250WC0FA	185.0	181.0	168.0	159.0	143.0	110.0	92.0	79.0	61.5	50.3	42.9	30.3	25.5	13.7
6 OPzS 300 LA	NVZS020300WC0FA	215.0	210.0	195.0	185.0	167.0	130.0	109.0	93.7	72.6	59.4	50.9	35.9	30.4	16.3
5 OPzS 350 LA	NVZS020350WC0FA	215.0	211.0	202.0	194.0	178.0	148.0	124.0	107.0	84.4	70.2	60.8	43.7	36.5	20.0
6 OPzS 420 LA	NVZS020420WC0FA	244.0	240.0	232.0	224.0	207.0	172.0	146.0	127.0	101.0	84.0	72.8	52.3	43.7	23.9
7 OPzS 490 LA	NVZS020490WC0FA	279.0	274.0	265.0	256.0	237.0	196.0	168.0	147.0	118.0	98.1	84.8	61.0	50.9	27.8
6 OPzS 600 LA	NVZS020600WC0FA	313.0	309.0	296.0	286.0	265.0	228.0	198.0	177.0	140.0	118.0	103.0	76.2	65.3	35.7
7 OPzS 700 LA	NVZS020700WC0FA	345.0	341.0	327.0	315.0	293.0	251.0	218.0	195.0	155.0	130.0	114.0	84.0	72.0	39.4
8 OPzS 800 LA	NVZS020800WC0FA	457.0	446.0	422.0	405.0	373.0	318.0	275.0	241.0	191.0	161.0	141.0	103.0	87.4	47.8
9 OPzS 900 LA	NVZS020900WC0FA	486.0	480.0	455.0	436.0	402.0	342.0	296.0	260.0	206.0	173.0	152.0	111.0	94.1	51.5
10 OPzS 1000 LA	NVZS021000WC0FA	546.0	539.0	513.0	493.0	456.0	390.0	338.0	299.0	237.0	199.0	175.0	128.0	109.0	59.9
12 OPzS 1200 LA	NVZS021200WC0FA	631.0	623.0	597.0	575.0	534.0	459.0	399.0	356.0	282.0	237.0	208.0	153.0	132.0	71.9
12 OPzS 1500 LA	NVZS021500WC0FA	599.0	596.0	583.0	568.0	544.0	469.0	428.0	388.0	323.0	277.0	246.0	184.0	156.0	85.0
14 OPzS 1750 LA	NVZS021750WC0FA	635.0	632.0	617.0	602.0	576.0	497.0	454.0	410.0	342.0	293.0	261.0	194.0	166.0	90.0
16 OPzS 2000 LA	NVZS022000WC0FA	865.0	861.0	835.0	811.0	768.0	648.0	585.0	522.0	427.0	366.0	326.0	243.0	207.0	112.0
18 OPzS 2250 LA	NVZS022250WC0FA	908.0	903.0	878.0	853.0	808.0	688.0	623.0	559.0	465.0	399.0	355.0	265.0	225.0	122.0
20 OPzS 2500 LA	NVZS022500WC0FA	1075.0	1070.0	1040.0	1010.0	956.0	806.0	728.0	649.0	532.0	456.0	406.0	302.0	258.0	140.0
22 OPzS 2750 LA	NVZS022750WC0FA	1155.0	1150.0	1115.0	1080.0	1025.0	864.0	779.0	695.0	570.0	489.0	435.0	324.0	276.0	150.0
24 OPzS 3000 LA	NVZS023000WC0FA	1240.0	1235.0	1200.0	1165.0	1100.0	942.0	852.0	764.0	636.0	546.0	486.0	362.0	308.0	167.0

Eléments OPzS

1,83 V/elt – Décharge en A à 20°C															
Type	Codification	3min	10min	15min	20min	30min	1h	1h30	2h	3h	4h	5h	8h	10h	20h
2 OPzS 100 LA	NVZS020100WC0FA	104	101	93.0	86.9	76.8	57.5	47.4	39.9	31.2	25.4	21.6	14.9	12.5	6.7
3 OPzS 150 LA	NVZS020150WC0FA	134	130	120.0	110.0	97.4	74.3	61.3	52.2	40.8	33.2	28.2	19.6	16.4	8.9
4 OPzS 200 LA	NVZS020200WC0FA	171	166	153.0	143.0	126.0	94.7	78.0	66.4	52.0	42.4	36.0	25.0	20.9	11.3
5 OPzS 250 LA	NVZS020250WC0FA	207	201	185.0	173.0	154.0	116.0	95.7	81.9	63.7	52.0	44.3	30.8	25.9	14.0
6 OPzS 300 LA	NVZS020300WC0FA	241	231	215.0	201.0	180.0	136.0	113.0	97.3	75.2	61.4	52.5	36.5	30.9	16.7
5 OPzS 350 LA	NVZS020350WC0FA	238	232	221.0	213.0	194.0	158.0	131.0	113.0	87.9	72.6	62.5	44.5	37.1	20.3
6 OPzS 420 LA	NVZS020420WC0FA	272	265	255.0	245.0	225.0	183.0	154.0	133.0	105.0	86.8	74.8	53.2	44.4	24.3
7 OPzS 490 LA	NVZS020490WC0FA	310	303	291.0	280.0	257.0	209.0	178.0	154.0	123.0	102.0	87.1	62.0	51.7	28.4
6 OPzS 600 LA	NVZS020600WC0FA	347	341	325.0	312.0	289.0	245.0	211.0	187.0	147.0	123.0	107.0	77.8	66.4	36.4
7 OPzS 700 LA	NVZS020700WC0FA	382	376	359.0	344.0	319.0	270.0	233.0	206.0	162.0	135.0	118.0	85.8	73.2	40.1
8 OPzS 800 LA	NVZS020800WC0FA	505	493	464.0	443.0	407.0	342.0	292.0	255.0	199.0	166.0	145.0	105.0	88.8	48.7
9 OPzS 900 LA	NVZS020900WC0FA	540	531	500.0	477.0	438.0	368.0	315.0	275.0	214.0	179.0	157.0	113.0	95.6	52.4
10 OPzS 1000 LA	NVZS021000WC0FA	605	595	563.0	539.0	497.0	420.0	360.0	317.0	248.0	207.0	180.0	131.0	111.0	61.0
12 OPzS 1200 LA	NVZS021200WC0FA	698	686	655.0	629.0	583.0	494.0	426.0	376.0	295.0	247.0	215.0	157.0	134.0	73.3
12 OPzS 1500 LA	NVZS021500WC0FA	673	668	652.0	633.0	602.0	513.0	465.0	418.0	343.0	292.0	258.0	191.0	162.0	88.3
14 OPzS 1750 LA	NVZS021750WC0FA	713	708	691.0	671.0	638.0	543.0	493.0	442.0	364.0	310.0	274.0	201.0	172.0	93.4
16 OPzS 2000 LA	NVZS022000WC0FA	973	966	934.0	904.0	850.0	708.0	634.0	562.0	454.0	387.0	342.0	252.0	214.0	116.0
18 OPzS 2250 LA	NVZS022250WC0FA	1015	1010	982.0	951.0	894.0	752.0	677.0	602.0	495.0	421.0	373.0	275.0	233.0	127.0
20 OPzS 2500 LA	NVZS022500WC0FA	1205	1200	1165.0	1125.0	1060.0	881.0	790.0	700.0	566.0	482.0	426.0	313.0	267.0	145.0
22 OPzS 2750 LA	NVZS022750WC0FA	1295	1285	1245.0	1205.0	1135.0	944.0	846.0	750.0	606.0	516.0	457.0	336.0	286.0	156.0
24 OPzS 3000 LA	NVZS023000WC0FA	1390	1380	1345.0	1300.0	1220.0	1030.0	924.0	825.0	675.0	575.0	510.0	375.0	319.0	174.0

1,80 V/elt – Décharge en A à 20°C															
Type	Codification	3min	10min	15min	20min	30min	1h	1h30	2h	3h	4h	5h	8h	10h	20h
2 OPzS 100 LA	NVZS020100WC0FA	122	116	106	97.7	84.8	61.5	50.1	42.0	32.8	26.6	22.6	15.3	12.8	7.0
3 OPzS 150 LA	NVZS020150WC0FA	155	148	135	124.0	107.0	79.2	64.8	54.9	42.9	34.8	29.5	20.1	16.8	9.2
4 OPzS 200 LA	NVZS020200WC0FA	199	190	174	161.0	140.0	101.0	82.5	69.9	54.6	44.4	37.6	25.6	21.4	11.8
5 OPzS 250 LA	NVZS020250WC0FA	241	230	211	195.0	170.0	124.0	101.0	86.3	66.9	54.5	46.3	31.6	26.5	14.6
6 OPzS 300 LA	NVZS020300WC0FA	281	268	245	227.0	199.0	146.0	120.0	103.0	79.0	64.3	54.9	37.4	31.6	17.4
5 OPzS 350 LA	NVZS020350WC0FA	273	264	251	240.0	216.0	172.0	141.0	120.0	93.1	76.2	65.0	45.6	38.0	20.9
6 OPzS 420 LA	NVZS020420WC0FA	314	303	289	277.0	252.0	200.0	166.0	142.0	111.0	90.9	77.8	54.6	45.5	25.0
7 OPzS 490 LA	NVZS020490WC0FA	358	346	330	316.0	287.0	229.0	192.0	164.0	130.0	106.4	90.6	63.6	53.0	29.2
6 OPzS 600 LA	NVZS020600WC0FA	398	388	368	352.0	325.0	271.0	232.0	202.0	156.0	129.0	112.0	80.2	68.0	37.4
7 OPzS 700 LA	NVZS020700WC0FA	439	428	406	389.0	359.0	299.0	256.0	223.0	173.0	144.0	123.0	88.5	75.0	41.3
8 OPzS 800 LA	NVZS020800WC0FA	572	564	528	501.0	457.0	378.0	319.0	277.0	211.0	175.0	152.0	108.0	91.0	50.1
9 OPzS 900 LA	NVZS020900WC0FA	623	608	568	539.0	492.0	407.0	343.0	298.0	227.0	188.0	164.0	117.0	98.0	53.9
10 OPzS 1000 LA	NVZS021000WC0FA	695	678	639	609.0	559.0	464.0	394.0	343.0	263.0	218.0	189.0	135.0	114.0	62.7
12 OPzS 1200 LA	NVZS021200WC0FA	800	781	741	710.0	655.0	547.0	467.0	407.0	315.0	261.0	225.0	162.0	137.0	75.4
12 OPzS 1500 LA	NVZS021500WC0FA	785	777	756	731.0	690.0	578.0	520.0	462.0	374.0	316.0	277.0	201.0	170.0	93.2
14 OPzS 1750 LA	NVZS021750WC0FA	831	823	801	774.0	731.0	612.0	551.0	490.0	396.0	334.0	293.0	212.0	180.0	98.6
16 OPzS 2000 LA	NVZS022000WC0FA	1135	1125	1080	1040.0	974.0	798.0	709.0	622.0	495.0	418.0	367.0	265.0	225.0	123.0
18 OPzS 2250 LA	NVZS022250WC0FA	1185	1175	1140	1095.0	1025.0	848.0	757.0	666.0	539.0	455.0	399.0	289.0	245.0	134.0
20 OPzS 2500 LA	NVZS022500WC0FA	1390	1375	1345	1300.0	1210.0	993.0	884.0	775.0	616.0	520.0	456.0	330.0	280.0	153.0
22 OPzS 2750 LA	NVZS022750WC0FA	1510	1495	1445	1390.0	1300.0	1065.0	946.0	830.0	660.0	557.0	489.0	354.0	300.0	164.0
24 OPzS 3000 LA	NVZS023000WC0FA	1620	1605	1555	1500.0	1400.0	1160.0	1035.0	911.0	737.0	622.0	546.0	395.0	335.0	184.0

Eléments OPzS

1,75 V/elt – Décharge en A à 20°C															
Type	Codification	3min	10min	15min	20min	30min	1h	1h30	2h	3h	4h	5h	8h	10h	20h
2 OPzS 100 LA	NVZS020100WC0FA	147	137	125	113	96.1	66.4	52.9	44.2	34.3	27.7	23.5	15.9	13.1	7.2
3 OPzS 150 LA	NVZS020150WC0FA	188	175	158	144	122.0	85.3	68.5	57.8	44.9	36.4	30.7	21.0	17.3	9.5
4 OPzS 200 LA	NVZS020200WC0FA	243	226	205	186	158.0	109.0	87.2	73.5	57.1	46.3	39.1	26.7	22.1	12.1
5 OPzS 250 LA	NVZS020250WC0FA	294	274	249	225	193.0	134.0	107.0	90.8	70.0	56.8	48.1	32.9	27.3	15.0
6 OPzS 300 LA	NVZS020300WC0FA	343	319	290	263	226.0	158.0	127.0	108.0	82.6	67.0	57.1	39.0	32.6	17.8
5 OPzS 350 LA	NVZS020350WC0FA	333	316	296	281	247.0	190.0	153.0	129.0	97.3	79.7	68.0	47.1	39.1	21.5
6 OPzS 420 LA	NVZS020420WC0FA	383	364	341	323	288.0	221.0	180.0	152.0	116.0	95.0	81.4	56.4	46.9	25.7
7 OPzS 490 LA	NVZS020490WC0FA	438	416	390	369	328.0	252.0	207.0	176.0	136.0	111.0	94.9	65.7	54.6	29.9
6 OPzS 600 LA	NVZS020600WC0FA	480	462	437	416	381.0	306.0	258.0	220.0	167.0	136.0	116.0	83.0	70.0	38.4
7 OPzS 700 LA	NVZS020700WC0FA	530	510	482	459	420.0	338.0	285.0	242.0	184.0	150.0	128.0	91.5	77.3	42.4
8 OPzS 800 LA	NVZS020800WC0FA	703	677	630	592	534.0	430.0	353.0	303.0	226.0	184.0	157.0	112.0	92.8	51.4
9 OPzS 900 LA	NVZS020900WC0FA	758	730	678	637	575.0	463.0	380.0	326.0	243.0	198.0	170.0	121.0	100.0	55.4
10 OPzS 1000 LA	NVZS021000WC0FA	843	812	761	719	654.0	526.0	438.0	374.0	281.0	229.0	196.0	140.0	117.0	64.4
12 OPzS 1200 LA	NVZS021200WC0FA	968	932	881	838	767.0	617.0	521.0	443.0	336.0	273.0	233.0	167.0	141.0	77.4
12 OPzS 1500 LA	NVZS021500WC0FA	966	952	923	884	824.0	676.0	598.0	524.0	413.0	346.0	301.0	212.0	178.0	97.4
14 OPzS 1750 LA	NVZS021750WC0FA	1025	1010	977	936	873.0	716.0	634.0	554.0	437.0	366.0	319.0	225.0	188.0	103.0
16 OPzS 2000 LA	NVZS022000WC0FA	1395	1375	1320	1260	1165.0	933.0	817.0	705.0	547.0	458.0	398.0	281.0	235.0	129.0
18 OPzS 2250 LA	NVZS022250WC0FA	1460	1440	1390	1325	1225.0	993.0	871.0	755.0	595.0	498.0	434.0	306.0	256.0	141.0
20 OPzS 2500 LA	NVZS022500WC0FA	1735	1710	1645	1565	1450.0	1165.0	1015.0	877.0	680.0	569.0	496.0	350.0	293.0	161.0
22 OPzS 2750 LA	NVZS022750WC0FA	1855	1830	1765	1680	1550.0	1245.0	1090.0	940.0	729.0	610.0	531.0	375.0	313.0	172.0
24 OPzS 3000 LA	NVZS023000WC0FA	2000	1970	1900	1810	1675.0	1360.0	1190.0	1030.0	814.0	681.0	593.0	419.0	350.0	192.0

1,70 V/elt – Décharge en A à 20°C															
Type	Codification	3min	10min	15min	20min	30min	1h	1h30	2h	3h	4h	5h	8h	10h	20h
2 OPzS 100 LA	NVZS020100WC0FA	173	157	139	125	105	69.7	54.8	45.2	35.2	28.3	23.9	16.0	13.3	7.3
3 OPzS 150 LA	NVZS020150WC0FA	220	200	177	160	134	89.4	71.0	59.1	46.0	37.0	31.2	21.1	17.5	9.6
4 OPzS 200 LA	NVZS020200WC0FA	284	258	229	206	172	115.0	90.3	75.2	58.6	47.3	39.7	26.9	22.3	12.2
5 OPzS 250 LA	NVZS020250WC0FA	344	313	278	250	210	141.0	111.0	93.0	71.8	57.9	48.9	33.1	27.6	15.1
6 OPzS 300 LA	NVZS020300WC0FA	403	366	325	292	247	166.0	132.0	111.0	84.8	68.4	58.0	39.3	32.9	18.0
5 OPzS 350 LA	NVZS020350WC0FA	394	368	339	316	274	202.0	161.0	134.0	100.0	81.4	69.5	47.1	39.9	22.0
6 OPzS 420 LA	NVZS020420WC0FA	453	423	390	364	319	235.0	189.0	158.0	120.0	97.7	83.3	57.8	47.8	26.4
7 OPzS 490 LA	NVZS020490WC0FA	517	483	446	416	364	269.0	218.0	183.0	140.0	114.0	97.0	67.3	55.7	30.7
6 OPzS 600 LA	NVZS020600WC0FA	562	535	507	479	433	337.0	279.0	233.0	173.0	139.0	118.0	84.3	70.7	39.1
7 OPzS 700 LA	NVZS020700WC0FA	619	590	559	528	478	371.0	308.0	257.0	191.0	154.0	130.0	93.0	78.0	43.1
8 OPzS 800 LA	NVZS020800WC0FA	824	785	728	678	606	471.0	379.0	322.0	237.0	190.0	160.0	114.0	94.6	52.3
9 OPzS 900 LA	NVZS020900WC0FA	888	846	784	730	653	508.0	409.0	347.0	255.0	204.0	172.0	123.0	102.0	56.4
10 OPzS 1000 LA	NVZS021000WC0FA	988	941	881	826	743	577.0	471.0	397.0	294.0	237.0	199.0	142.0	119.0	65.6
12 OPzS 1200 LA	NVZS021200WC0FA	1135	1080	1020	964	873	678.0	562.0	469.0	349.0	281.0	237.0	170.0	142.0	78.8
12 OPzS 1500 LA	NVZS021500WC0FA	1145	1125	1085	1030	950	768.0	665.0	573.0	442.0	367.0	318.0	219.0	182.0	100.0
14 OPzS 1750 LA	NVZS021750WC0FA	1215	1190	1150	1090	1005	814.0	704.0	607.0	468.0	389.0	337.0	232.0	193.0	106.0
16 OPzS 2000 LA	NVZS022000WC0FA	1655	1625	1555	1470	1345	1060.0	907.0	771.0	585.0	486.0	421.0	290.0	241.0	132.0
18 OPzS 2250 LA	NVZS022250WC0FA	1735	1700	1635	1545	1410	1125.0	968.0	826.0	637.0	529.0	458.0	316.0	262.0	144.0
20 OPzS 2500 LA	NVZS022500WC0FA	2060	2020	1930	1830	1670	1320.0	1130.0	960.0	728.0	605.0	524.0	361.0	300.0	165.0
22 OPzS 2750 LA	NVZS022750WC0FA	2205	2165	2070	1960	1785	1415.0	1210.0	1025.0	780.0	648.0	561.0	387.0	321.0	176.0
24 OPzS 3000 LA	NVZS023000WC0FA	2375	2330	2230	2115	1930	1540.0	1325.0	1130.0	871.0	723.0	626.0	432.0	358.0	197.0

Eléments OPzS

1,65 V/elt – Décharge en A à 20°C															
Type	Codification	3min	10min	15min	20min	30min	1h	1h30	2h	3h	4h	5h	8h	10h	20h
2 OPzS 100 LA	NVZS020100WC0FA	196	174	151	135	111	71.8	55.8	46.4	35.7	28.6	24.1	16.0	13.3	7.3
3 OPzS 150 LA	NVZS020150WC0FA	249	221	194	172	142	91.7	72.3	60.1	46.7	37.5	31.5	21.1	17.5	9.6
4 OPzS 200 LA	NVZS020200WC0FA	322	286	249	222	182	118.0	92.0	76.4	59.4	47.7	40.1	26.9	22.3	12.2
5 OPzS 250 LA	NVZS020250WC0FA	392	348	303	270	222	145.0	113.0	94.6	72.8	58.6	49.4	33.1	27.6	15.1
6 OPzS 300 LA	NVZS020300WC0FA	458	407	355	315	261	171.0	134.0	113.0	86.0	69.3	58.6	39.3	32.9	18.0
5 OPzS 350 LA	NVZS020350WC0FA	454	417	379	349	297	211.0	167.0	137.0	103.0	82.9	69.9	47.1	39.9	22.0
6 OPzS 420 LA	NVZS020420WC0FA	522	480	437	402	346	246.0	196.0	162.0	123.0	99.1	83.7	57.8	47.8	26.4
7 OPzS 490 LA	NVZS020490WC0FA	596	548	499	459	395	280.0	226.0	187.0	143.0	115.0	97.5	67.3	55.7	30.7
6 OPzS 600 LA	NVZS020600WC0FA	643	605	576	541	482	364.0	294.0	243.0	177.0	141.0	119.0	86.4	71.4	39.4
7 OPzS 700 LA	NVZS020700WC0FA	710	668	635	596	532	401.0	324.0	269.0	196.0	156.0	131.0	95.3	78.8	43.5
8 OPzS 800 LA	NVZS020800WC0FA	945	890	824	760	673	502.0	399.0	335.0	244.0	194.0	162.0	116.0	95.6	52.8
9 OPzS 900 LA	NVZS020900WC0FA	1015	958	887	818	725	541.0	430.0	361.0	263.0	209.0	174.0	124.0	103.0	56.8
10 OPzS 1000 LA	NVZS021000WC0FA	1130	1065	999	929	826	620.0	496.0	414.0	302.0	241.0	201.0	145.0	120.0	66.1
12 OPzS 1200 LA	NVZS021200WC0FA	1295	1220	1160	1090	971	733.0	592.0	490.0	358.0	286.0	240.0	174.0	144.0	79.5
12 OPzS 1500 LA	NVZS021500WC0FA	1330	1300	1240	1175	1070	853.0	721.0	612.0	462.0	382.0	330.0	223.0	184.0	101.0
14 OPzS 1750 LA	NVZS021750WC0FA	1410	1375	1315	1245	1135	904.0	763.0	648.0	490.0	405.0	349.0	236.0	194.0	107.0
16 OPzS 2000 LA	NVZS022000WC0FA	1920	1875	1775	1675	1510	1180.0	984.0	824.0	612.0	506.0	436.0	295.0	243.0	133.0
18 OPzS 2250 LA	NVZS022250WC0FA	2015	1965	1870	1765	1590	1250.0	1050.0	882.0	666.0	550.0	475.0	321.0	265.0	145.0
20 OPzS 2500 LA	NVZS022500WC0FA	2390	2335	2215	2090	1885	1465.0	1220.0	1025.0	762.0	630.0	543.0	367.0	302.0	166.0
22 OPzS 2750 LA	NVZS022750WC0FA	2555	2495	2370	2235	2015	1570.0	1310.0	1100.0	815.0	674.0	582.0	393.0	324.0	178.0
24 OPzS 3000 LA	NVZS023000WC0FA	2755	2690	2555	2415	2175	1710.0	1435.0	1205.0	911.0	753.0	650.0	439.0	362.0	199.0

1,60 V/elt – Décharge en A à 20°C															
Type	Codification	3min	10min	15min	20min	30min	1h	1h30	2h	3h	4h	5h	8h	10h	20h
2 OPzS 100 LA	NVZS020100WC0FA	216	188	162	143	116	73.3	56.4	46.5	36.0	29.4	24.0	16.0	13.3	7.3
3 OPzS 150 LA	NVZS020150WC0FA	275	239	207	182	147	93.4	72.9	60.7	47.0	37.3	31.4	21.1	17.5	9.6
4 OPzS 200 LA	NVZS020200WC0FA	355	309	267	235	190	121.0	92.8	77.3	59.9	47.6	39.9	26.9	22.3	12.2
5 OPzS 250 LA	NVZS020250WC0FA	434	377	325	286	232	148.0	114.0	95.7	73.4	58.3	49.2	33.1	27.6	15.1
6 OPzS 300 LA	NVZS020300WC0FA	508	442	381	335	272	176.0	136.0	114.0	86.6	68.8	58.3	39.3	32.9	18.0
5 OPzS 350 LA	NVZS020350WC0FA	515	466	418	377	319	217.0	171.0	139.0	105.0	83.4	69.2	47.1	39.9	22.0
6 OPzS 420 LA	NVZS020420WC0FA	592	536	481	435	370	253.0	200.0	165.0	125.0	99.3	82.8	57.8	47.8	26.4
7 OPzS 490 LA	NVZS020490WC0FA	676	612	549	496	423	288.0	231.0	190.0	146.0	116.0	96.5	67.3	55.7	30.7
6 OPzS 600 LA	NVZS020600WC0FA	723	673	645	602	528	388.0	305.0	252.0	179.0	142.0	119.0	86.4	71.4	39.4
7 OPzS 700 LA	NVZS020700WC0FA	799	743	712	665	583	428.0	336.0	278.0	197.0	156.0	131.0	95.3	78.8	43.5
8 OPzS 800 LA	NVZS020800WC0FA	1065	992	917	837	737	524.0	416.0	342.0	248.0	195.0	162.0	116.0	95.6	52.8
9 OPzS 900 LA	NVZS020900WC0FA	1150	1070	988	902	794	564.0	448.0	368.0	267.0	211.0	174.0	124.0	103.0	56.8
10 OPzS 1000 LA	NVZS021000WC0FA	1270	1185	1115	1030	905	653.0	516.0	426.0	305.0	242.0	201.0	145.0	120.0	66.1
12 OPzS 1200 LA	NVZS021200WC0FA	1455	1355	1300	1215	1065	781.0	614.0	508.0	360.0	286.0	240.0	174.0	144.0	79.5
12 OPzS 1500 LA	NVZS021500WC0FA	1515	1470	1395	1320	1190	933.0	767.0	642.0	476.0	391.0	337.0	224.0	184.0	101.0
14 OPzS 1750 LA	NVZS021750WC0FA	1605	1560	1475	1395	1260	988.0	812.0	680.0	504.0	414.0	356.0	238.0	194.0	107.0
16 OPzS 2000 LA	NVZS022000WC0FA	2185	2125	1995	1880	1680	1290.0	1045.0	864.0	630.0	518.0	445.0	297.0	243.0	133.0
18 OPzS 2250 LA	NVZS022250WC0FA	2290	2225	2100	1975	1765	1370.0	1115.0	926.0	686.0	564.0	485.0	323.0	265.0	145.0
20 OPzS 2500 LA	NVZS022500WC0FA	2725	2645	2485	2340	2090	1600.0	1305.0	1080.0	784.0	645.0	554.0	370.0	302.0	166.0
22 OPzS 2750 LA	NVZS022750WC0FA	2920	2835	2660	2510	2240	1715.0	1395.0	1155.0	840.0	690.0	594.0	396.0	324.0	178.0
24 OPzS 3000 LA	NVZS023000WC0FA	3135	3045	2870	2705	2415	1875.0	1525.0	1265.0	938.0	771.0	663.0	442.0	362.0	199.0